

# T10

Partition



Installation illustrate

Web : <https://www.mwworkstation.com/>

Tel : +86 13695211636

Mail : [robbor@mwworkstation.com](mailto:robbor@mwworkstation.com)

# T10

Partition



FAST AND CONVENIENT INSTALLATION SYSTEM  
DESK SYSTEM SCREEN SYSTEM

## PRODUCT

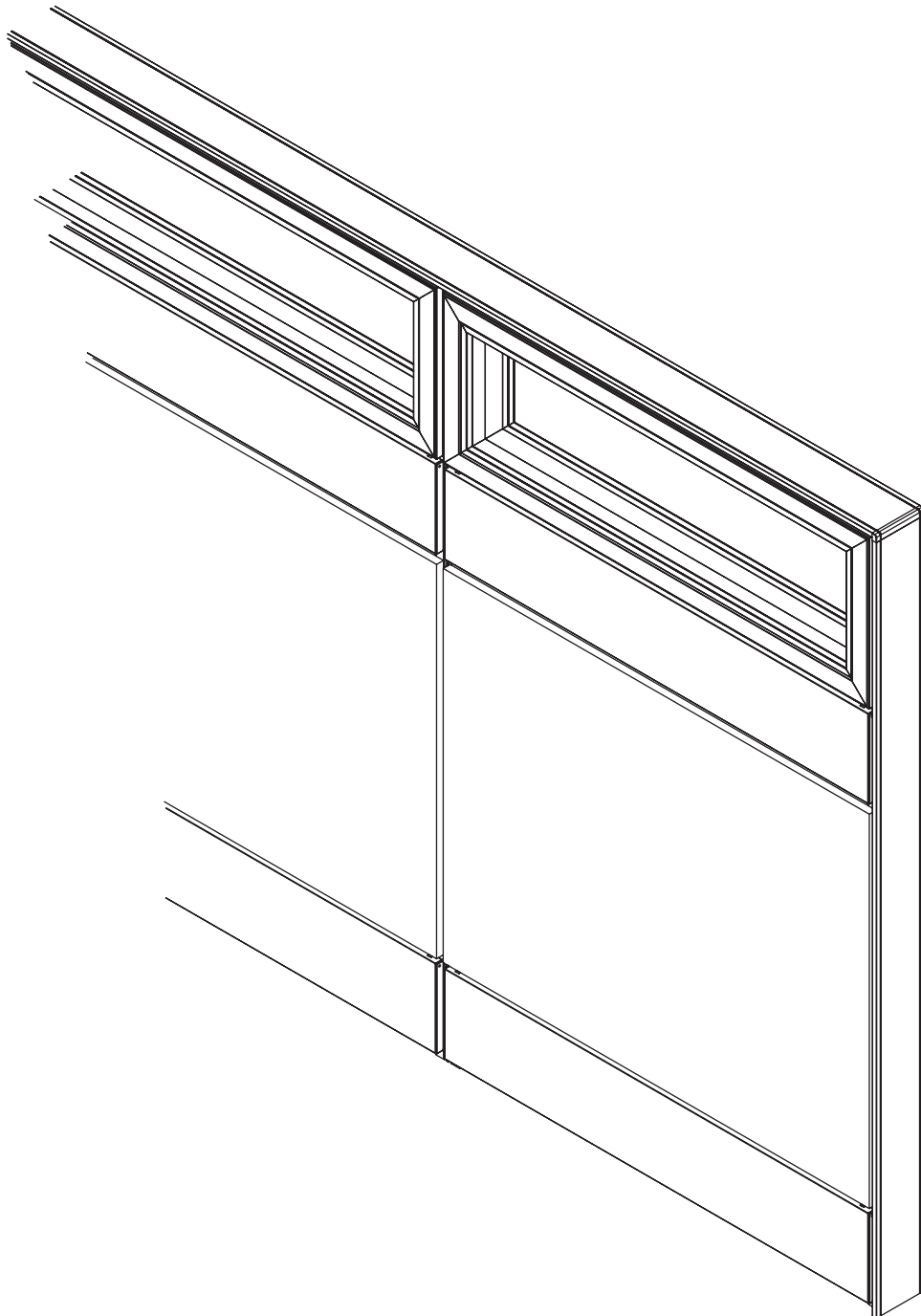

## Aluminum profiles parts

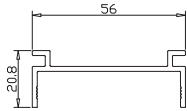

A pole  
3908#

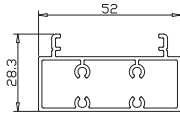

Top bar  
3915#

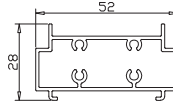

Bottom bar  
3917#

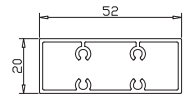

Connection bar  
3918#

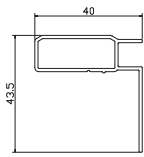

Glass groove  
3992#

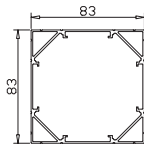

Column  
3910#

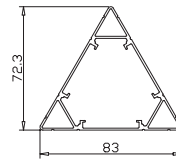

120° pole  
3912#

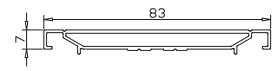

Side cover  
3911#

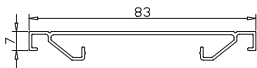

Top cover  
3909#

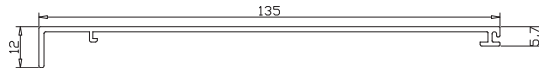

Cable channel  
3907#

## Plastic profiles parts

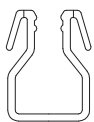

Mid sealing  
H116



Side sealing  
Pv54



Cable channel seal  
U119-25

## Accessories parts

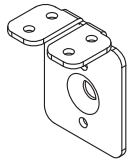

Single foot



Tile hook(L/R)

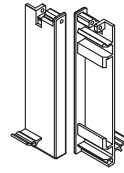

Cable channel side cap  
(L/R)

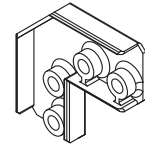

Glass groove  
connector

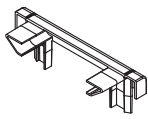

Side top cap

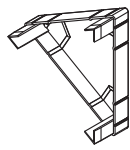

120° cap

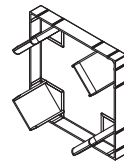

Square cap

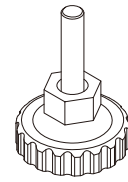

Adjustor

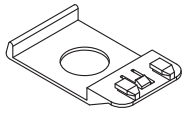

Connection position  
for A pole

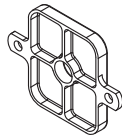

Connection position  
for column

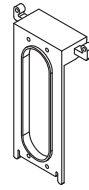

Cable channel  
connector

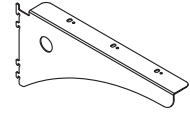

Big bracket(L/R)

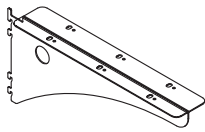

Double side bracket

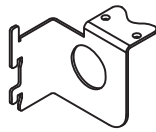

Small bracket  
(L/R)

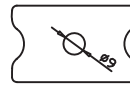

Panel connector F

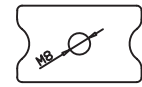

Panel connector M

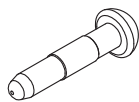

Dowel pin

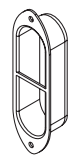

Wire guard

## General design character

### I.T10 details:

1.Aluminum frame, tile base partition

2.T10 thickness:83mm

### II.End trim:

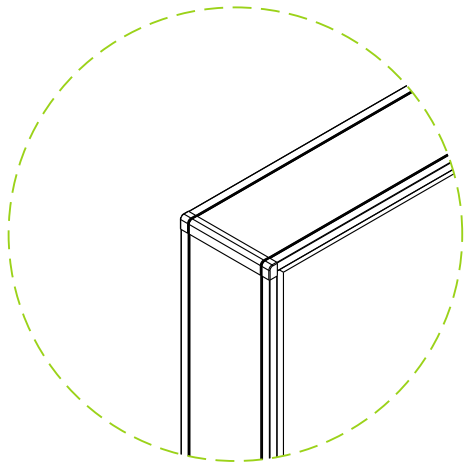

### III.Connections and trimming:

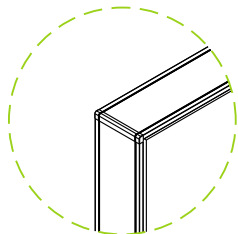

End trimming

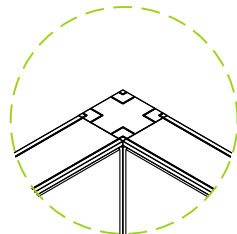

2 ways connection

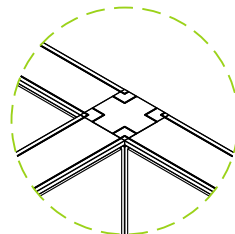

3 ways connection

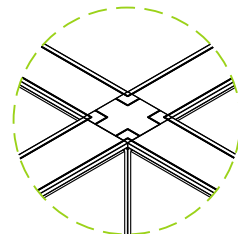

4 ways connection

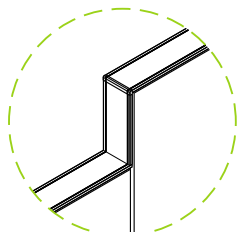

180° connection  
in variable height

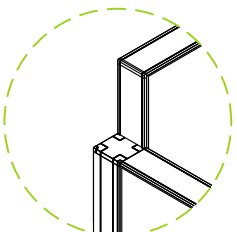

2 ways connection  
in variable height

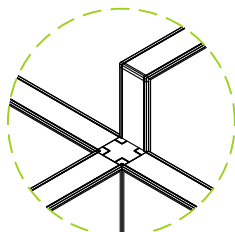

4 ways connection  
in different height

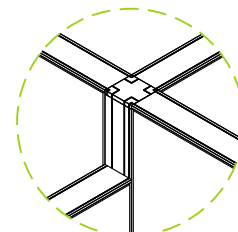

4 ways connection  
in different height

## Structure

### I.T10 structure details:

- 1.Panel-base system, aluminum frame includes powder coated and anodized.
- 2.Block material:(4mm)glass, melamine, fabric, metal sheet,white board and accessories rail.

### II.Partition assembling

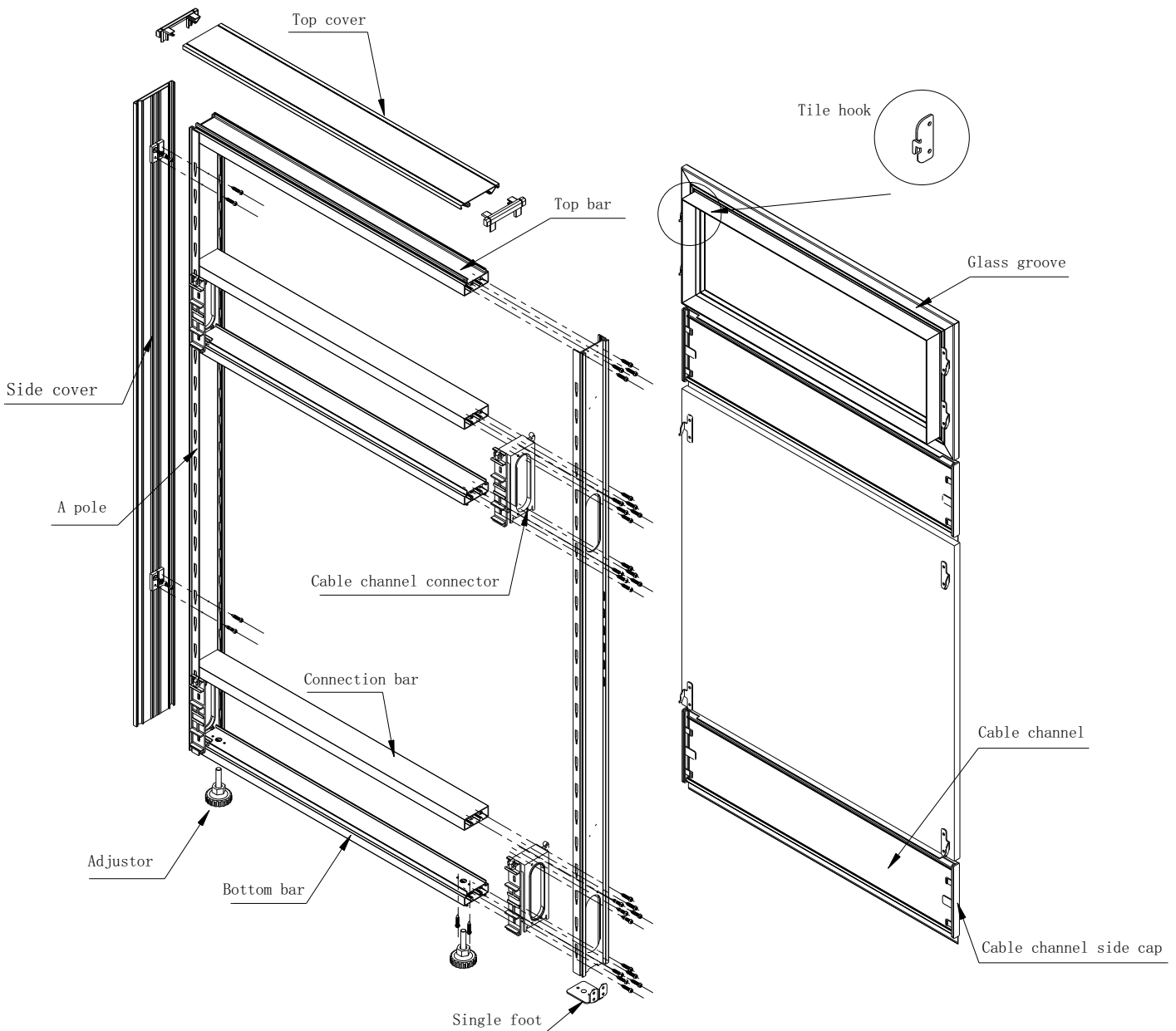

## Steps of assembling

I.

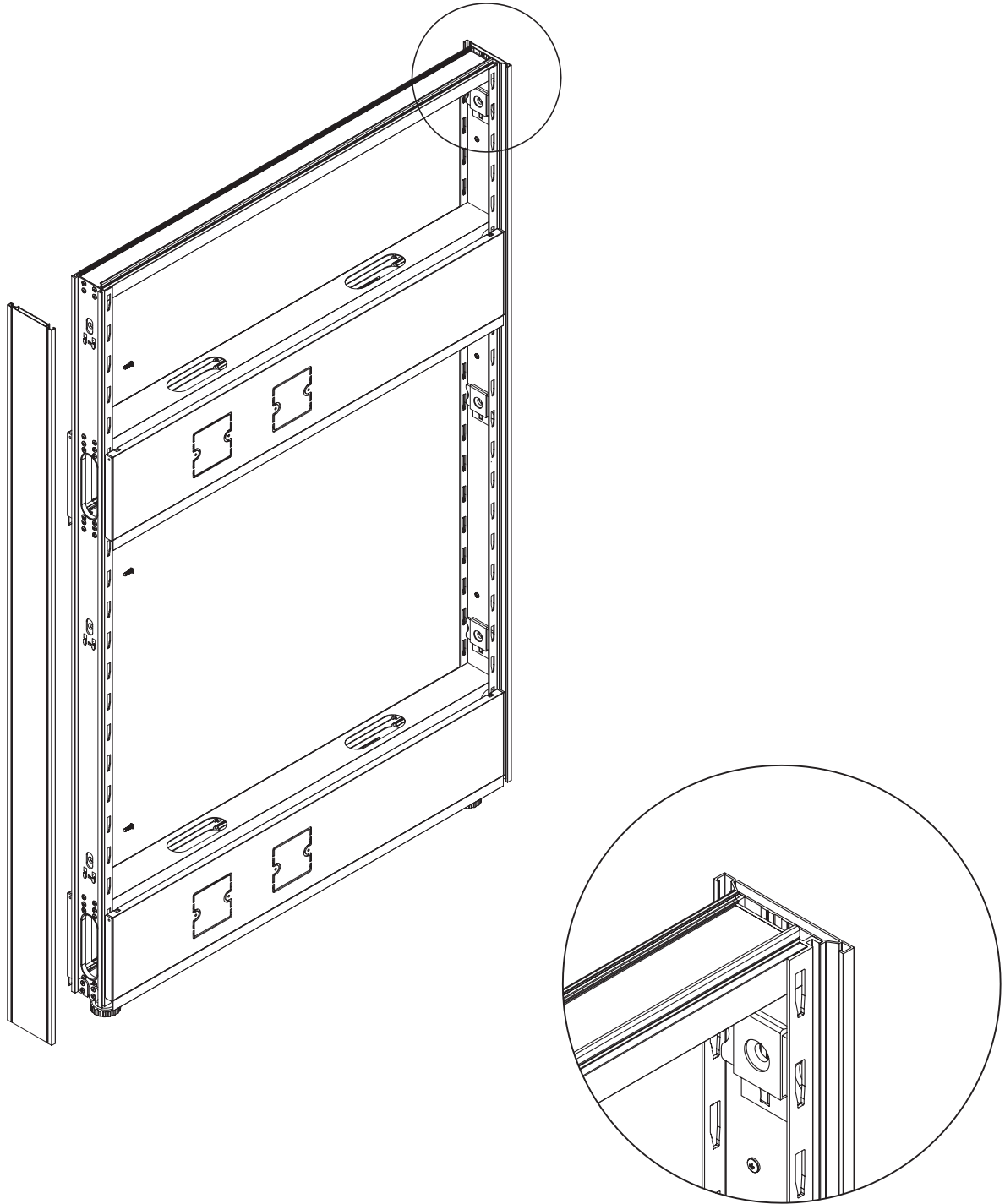

II.

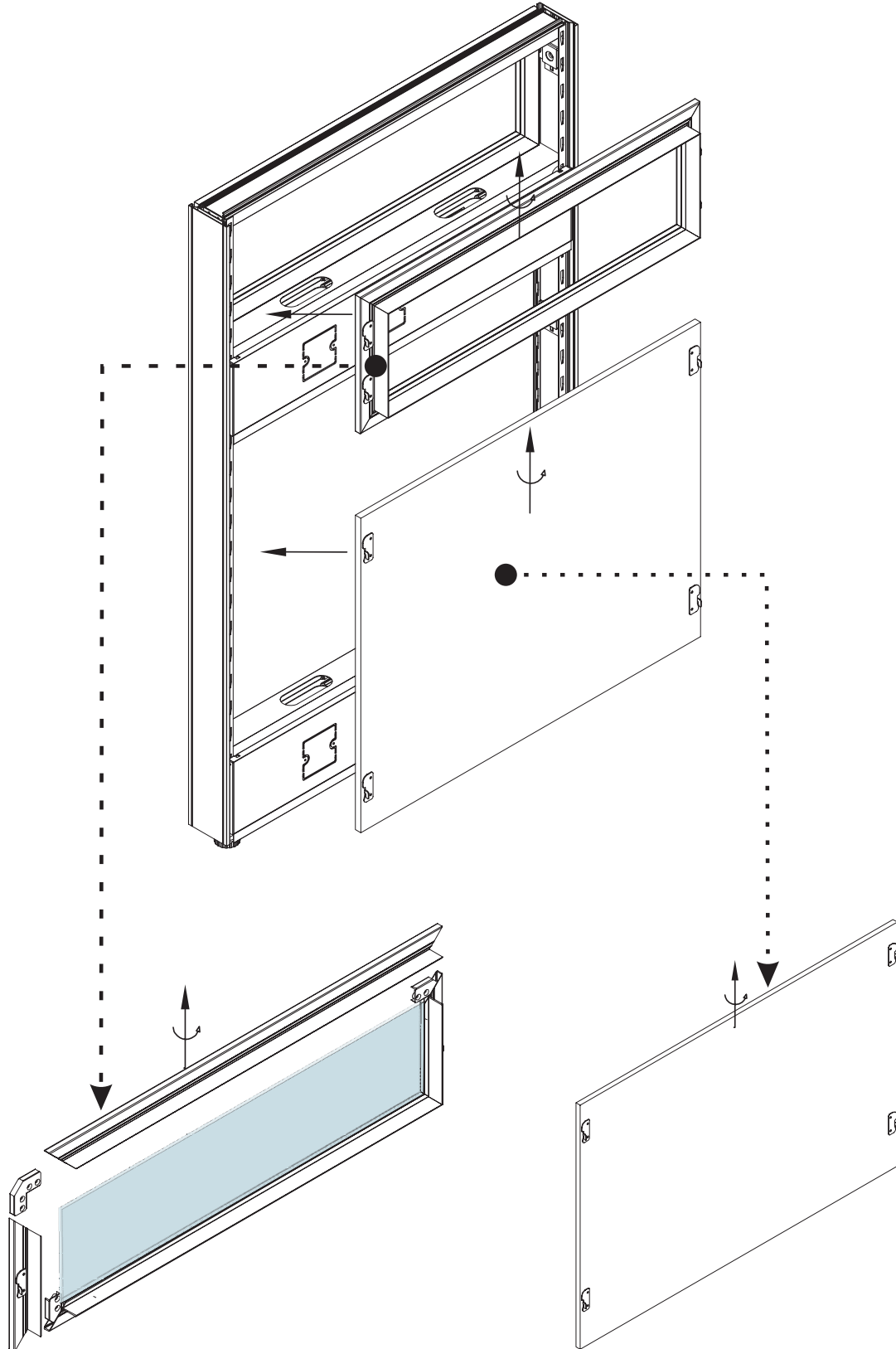



III.

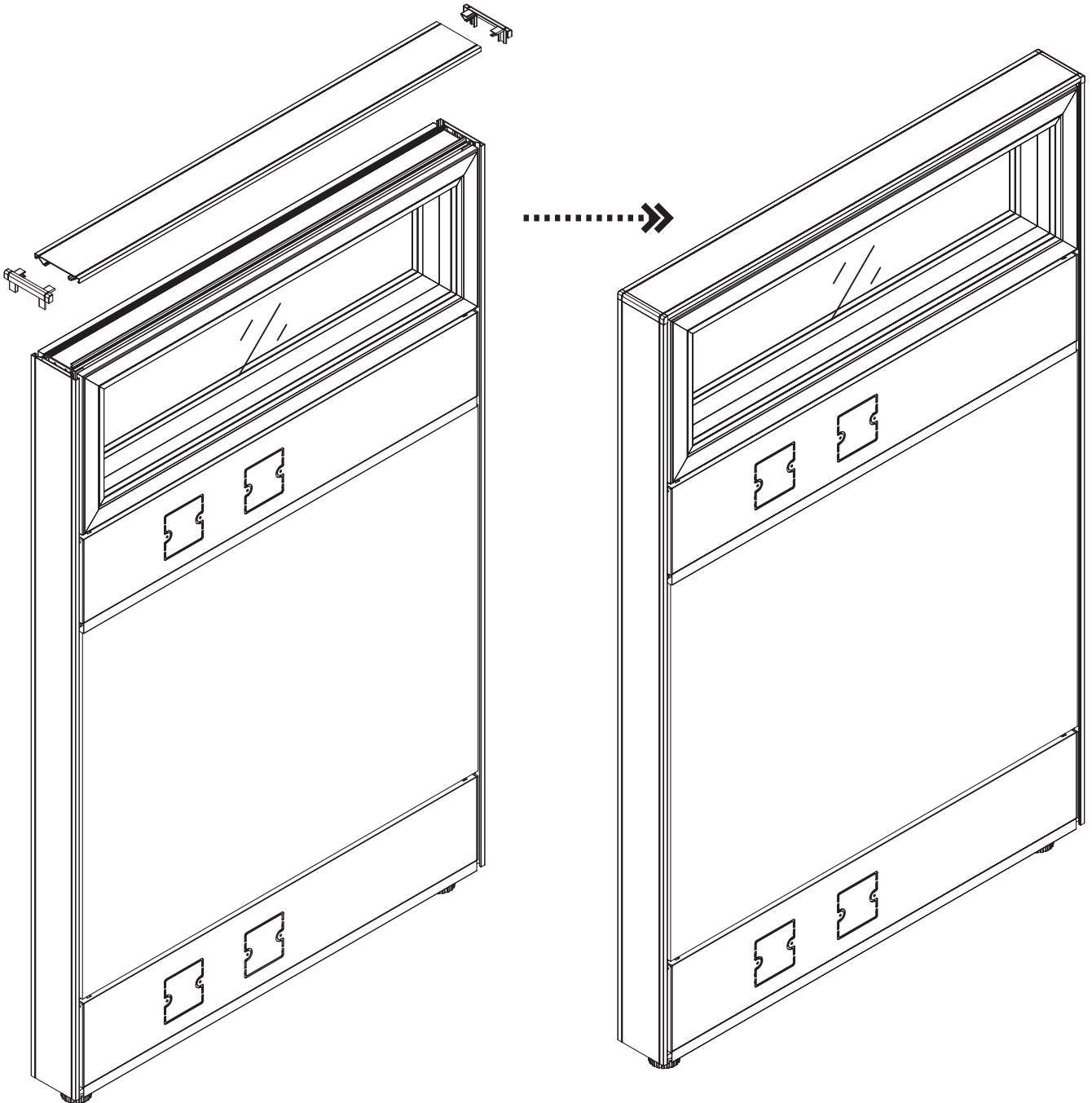

IV.

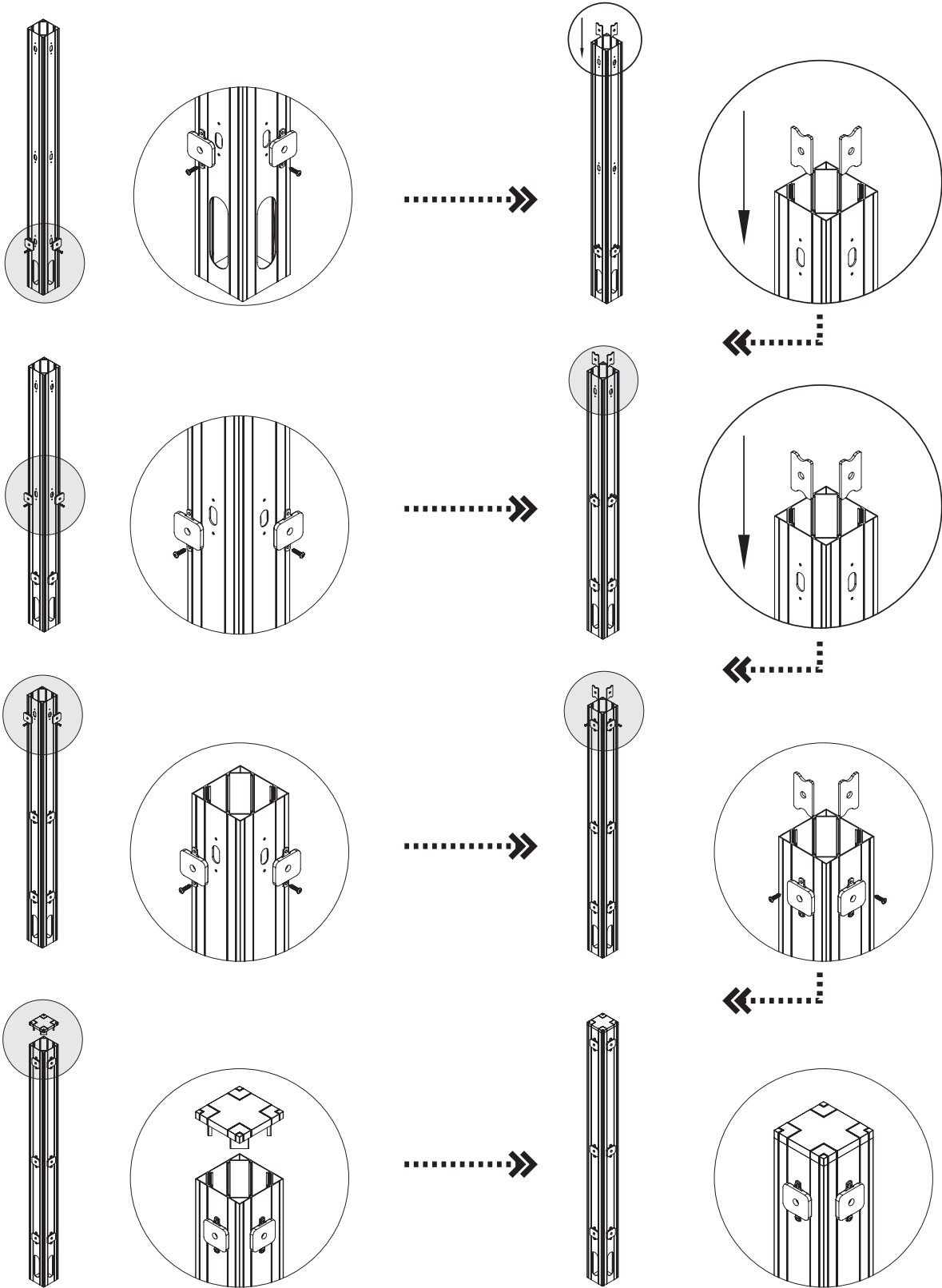

V.

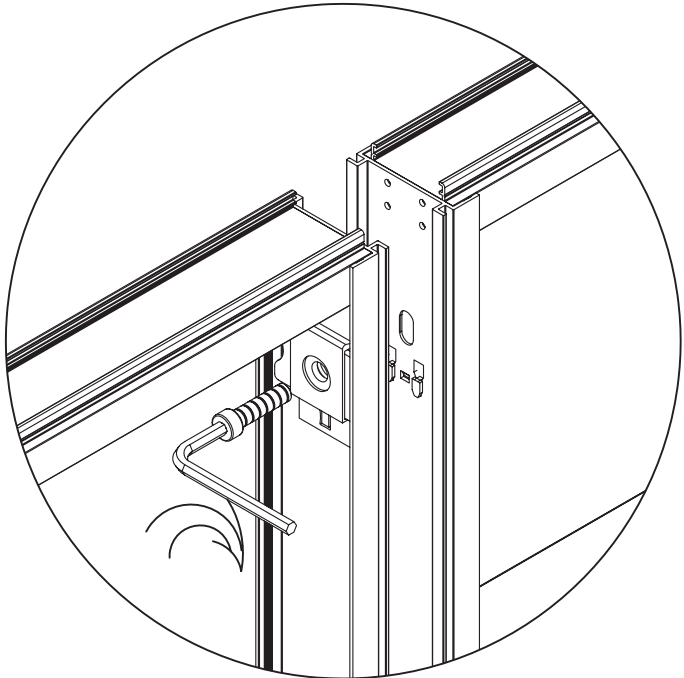
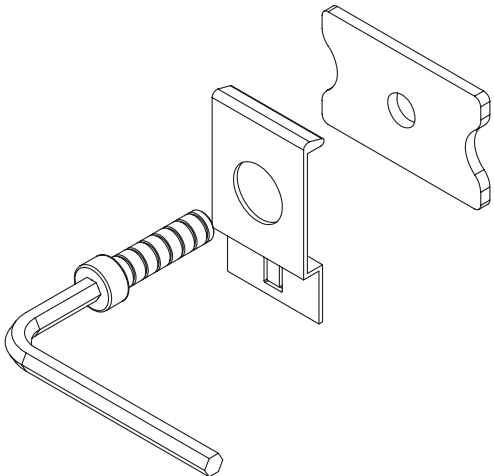
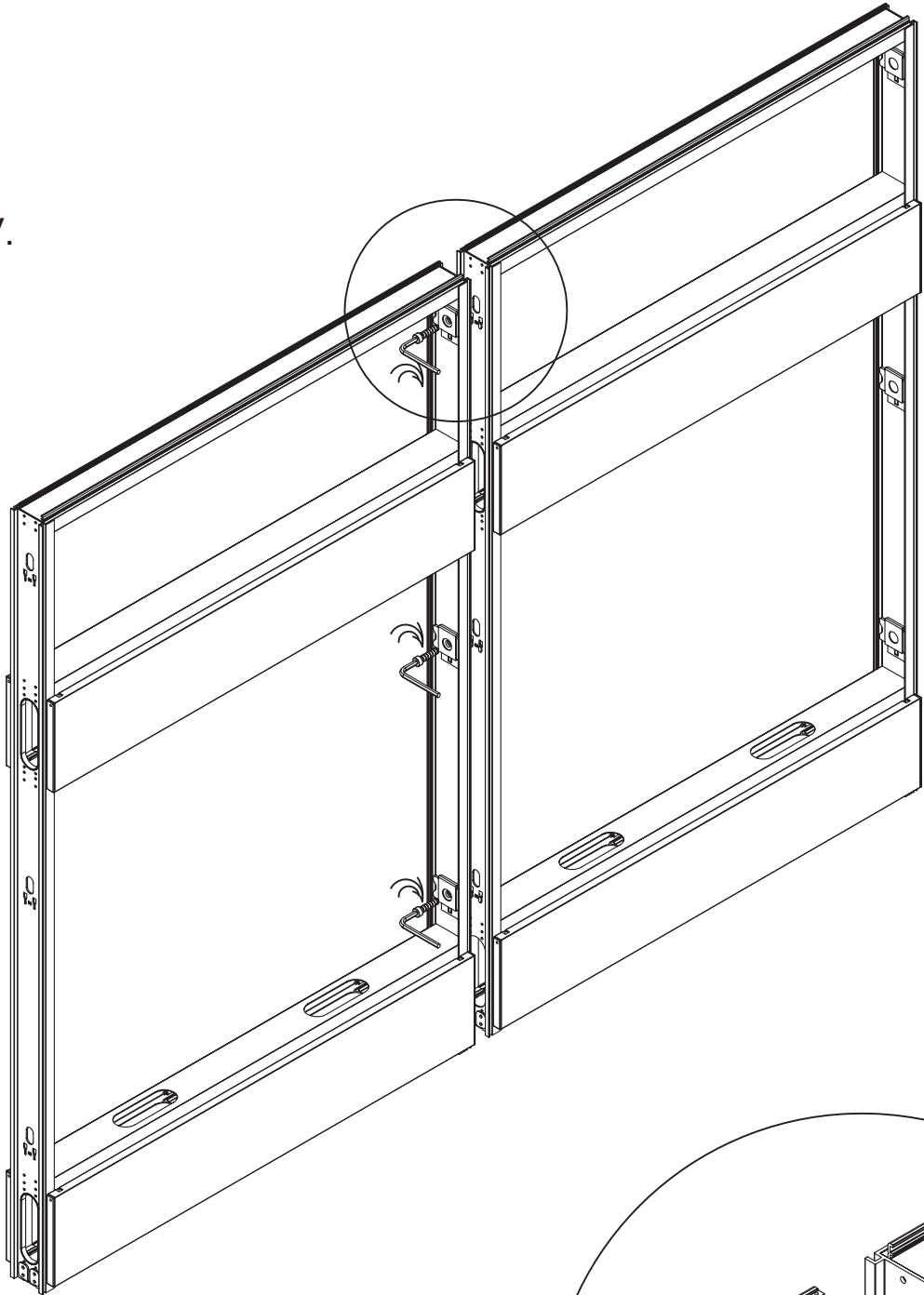

VI.

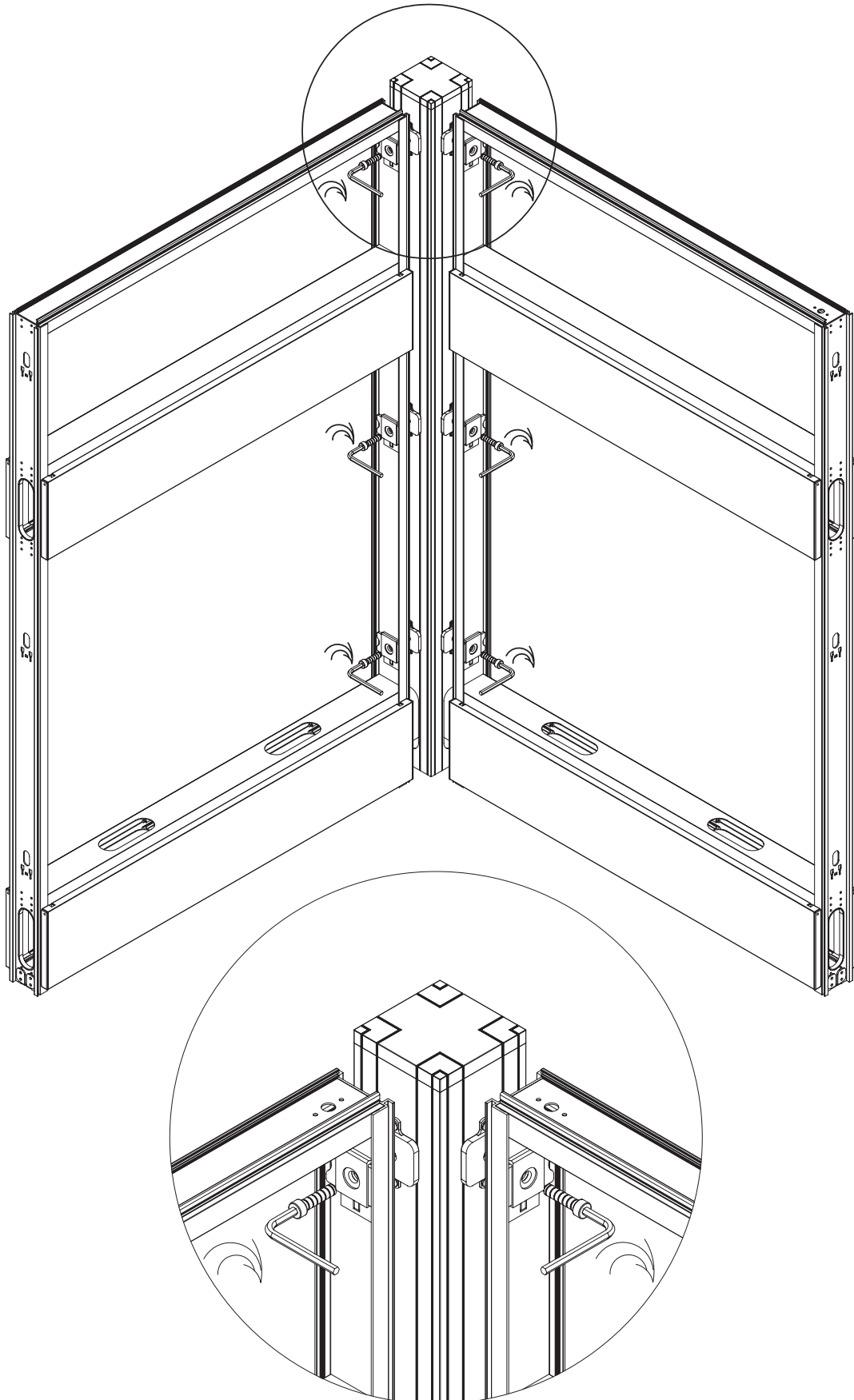

VII.

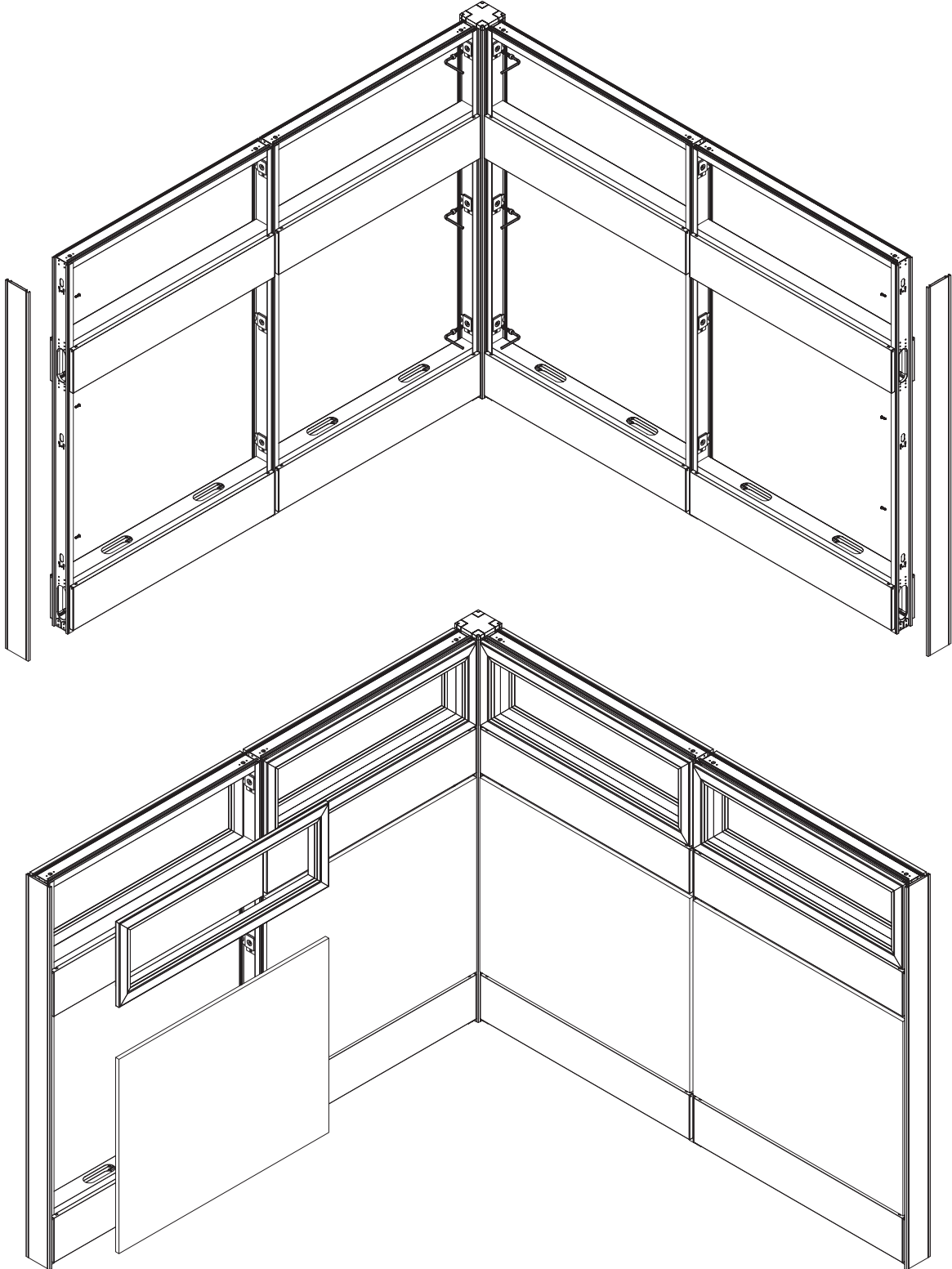

VIII.

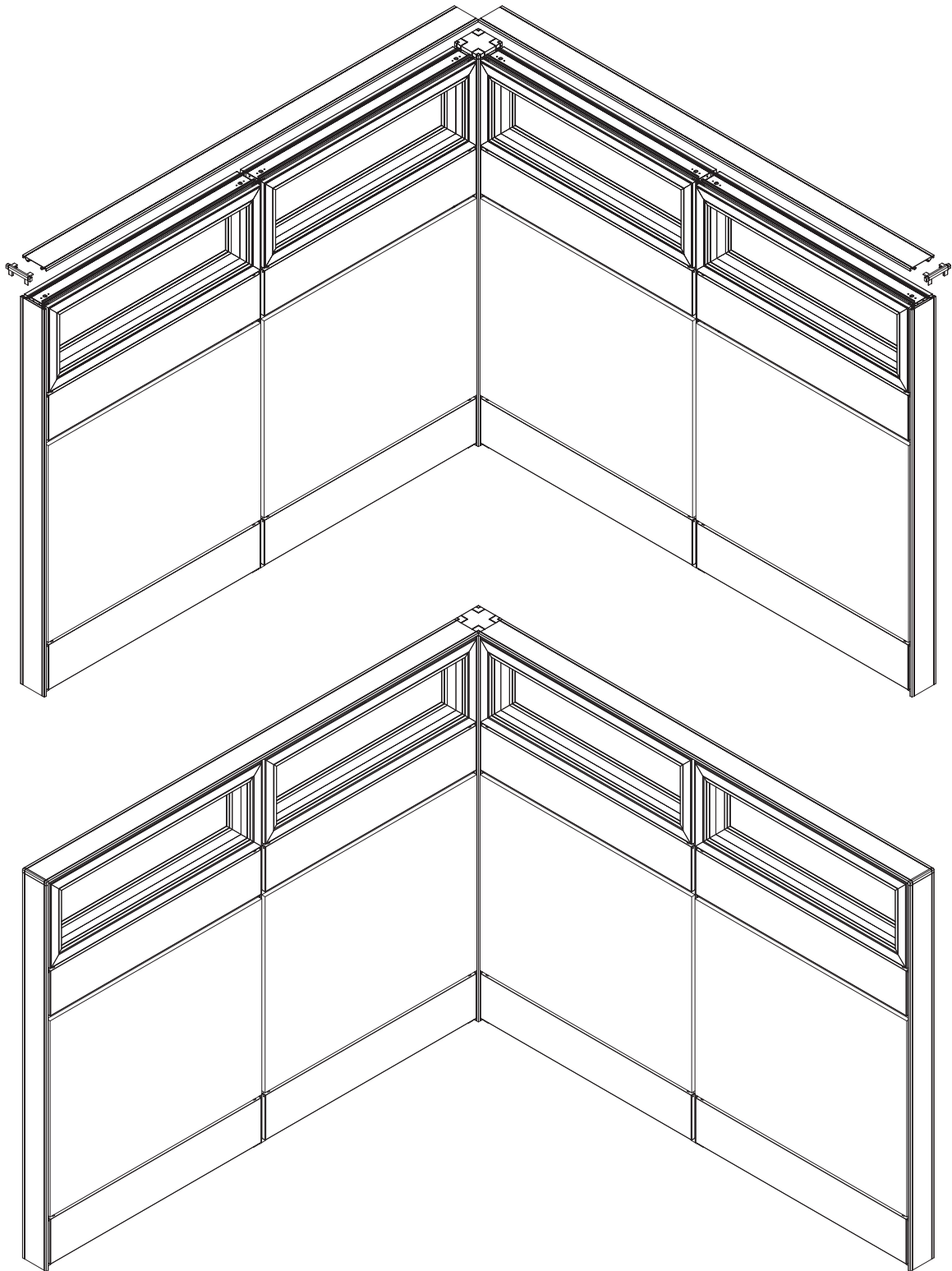

# M & W

**Web:** [mwworkstation.com](http://mwworkstation.com)

**Mail:** [robbor@mwworkstation.com](mailto:robbor@mwworkstation.com)

**Tel:** +86 13695211636

**WhatsApp:** + 86 13695211636

**Add:** NO.3 Xingye North Road Dawotang Industrial  
District Shishan Nanhai Foshan City Guangdong  
P.R China



WhatsApp



Facebook



Instagram



Twitter



Pinterest



Linkein



YouTube